

Inflatable Seated Butterfly Valves



SERIES
485
486
487
488

ANSI and Metric
Flange Compatible

posi-flate[®]
butterfly valves

Less friction, low torque, less wear, longer life.

Posi-plate's unique butterfly valve design uses air pressure to expand the seat against the disc, providing even pressure distribution for a bubble-tight seal, every time. Because the seat makes only casual contact with the disc during valve opening and closing, there is minimal disc impingement. This is in contrast to conventional butterfly valves where disc impingement leads to shaving of the seat, decreasing the overall performance and valve life.

Substantially less torque is required to open and close the Posi-plate butterfly valve, thus a smaller actuator can be used resulting in lower overall valve cost.

In actual comparison tests and documented field applications, the Posi-plate butterfly valve outperformed all other valves.

In fact, a Posi-plate valve life of one to three million cycles, even in extremely abrasive applications, is not uncommon. For dry solids, gases and slurry applications, the Posi-plate inflatable seated butterfly valve is unsurpassed.

Standard valve sizes range from 2" (50mm) to 30" (800mm) and fit both ANSI and metric flanges. A full line of actuators, limit switches and controls are available to suit individual applications.

How it works



Performance Features

- Inflatable seat compensates for disc and seat wear
- Longer valve life
- Minimal seat wear
- No disc impingement
- Ultra-low torque requirements
- Lower actuator costs
- More seal contact area
- Proven excellent for abrasive and dry solids
- Disc designed to prevent material buildup
- Double shaft seals
- Multiple bearings
- Fail-safe monitoring

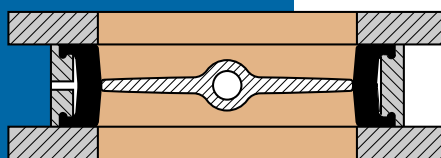

Closed, unsealed

As the valve rotates into the closed position, the disc makes only casual contact with the seat, reducing friction, wear and torque requirements.

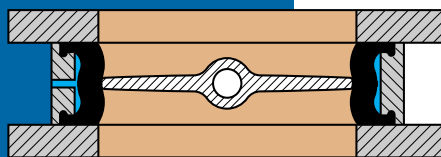

Closed, sealed

After the valve is closed, the seat inflates against the disc providing more sealing surface and an even pressure distribution against the disc.

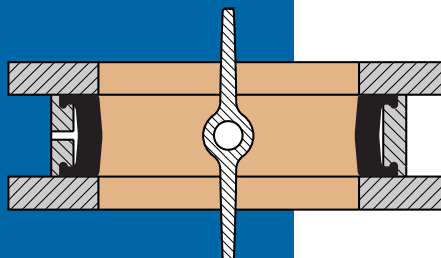

Open, unsealed

Before the valve opens, the seat is first deflated. The disc is then free to rotate to the open position.

SERIES 485

Design features for reliable performance

- A. ACTUATOR MOUNTING FLANGE:** Flange is designed for direct actuator mounting.
- B. RETAINING RING:** Retaining ring simplifies bearing and seal removal and ensures positive bearing retention.
- C. BEARINGS:** Multiple bearings substantially reduce operating friction and torque requirements, eliminating any metal-to-metal contact, thus preventing shaft galling and freezing.
- D. SHAFT SEALS:** O-ring shaft seals insure positive sealing under the most adverse conditions.
- E. SHAFT:** Corrosion resistant, high strength steel shaft is easily replaceable.
- F. SEAT O-RING SEAL:** O-ring provides long lasting positive seal of seat inflation pressure.
- G. MATERIAL SEAL:** Land seal prevents material contamination of seat o-ring seal.
- H. DISC/SHAFT:** Integral disc and shaft with smooth, contoured surface provides minimum resistance to flow and reduces material buildup.
- I. AIR INLET PORT:** Oversized inlet port allows quick valve pressurization/depressurization.
- J. DISC:** Smooth contoured surface assures extended seat life and disc is easily replaceable.
- K. DISC SCREWS:** Self-locking screws of high tensile steel provide strong link between disc and shaft, yet allow easy disassembly.
- L. HOUSING:** Rugged one-piece body fits standard 125/150 class ANSI flat-faced flanges and PN 10 metric flanges.
- M. HOUSING GASKET:** Die cut elastomeric gasket assures leakproof housing.
- N. HOUSING BOLTS:** High strength steel bolts maintain structural integrity of housing under the most adverse conditions.
- O. SPLIT HOUSING:** Rugged two-piece body fits standard 125/150 class ANSI flat-faced flanges and PN 10 metric flanges. Minimizes assembly time and allows for integral shaft and disc.
- P. RESILIENT SEAT:** Easily replaceable, the inflatable molded seat has a smooth contour locking design to minimize stress and hold the seat in place, eliminating any need for flange gaskets.



SERIES 486

Valve Size		Posi-flate Butterfly Valve Series 485, 486, 487 and 488 Dimensions* (Inches)													Approx. Weight (Pounds)	Normal Torque (Inch Pounds)	
Inch	mm	A	B	C	D	E	F	G	H	J	K	L	M	N		Min.	Max.
2"	50mm	4.52	4.50	2.91	1.62	6.50	4.00	2.12	3.25	1.17	.31	.78	.43	1.99	8	40	450
3"	80mm	5.65	5.56	3.57	1.75	8.19	4.00	2.12	3.25	1.17	.31	.81	.43	2.89	10	80	450
4"	100mm	6.88	7.58	4.42	2.00	8.88	4.00	2.12	3.25	1.17	.31	.70	.43	3.88	16	130	450
5"	125mm	7.75	7.95	6.05	2.12	9.62	4.00	2.12	3.25	1.17	.31	.86	.55	4.92	19	260	450
6"	150mm	8.75	7.95	6.05	2.12	10.69	4.00	2.12	3.25	1.17	.31	.86	.55	5.88	22	300	450
8"	200mm	11.12	9.87	7.24	2.50	14.00	5.25	2.75	4.31	1.75	.38	.88	.75	7.86	37	540	1300
10"	250mm	13.31	10.56	8.06	2.50	17.50	5.25	2.75	4.31	1.75	.38	.93	.75	9.81	45	860	1300
12"	300mm	15.50	14.28	9.52	3.00	20.25	4.00	4.00	2.84	2.84	.44	1.25	.87	11.83	80	1240	2480
14"	350mm	17.72	16.00	10.50	3.00	22.00	4.00	4.00	2.84	2.84	.44	1.02	.87	13.08	150	2100	6200
16"	400mm	19.75	16.93	12.40	4.00	24.75	7.63	4.62	3.48	3.48	.53	1.29	1.06	15.02	180	3500	9600
18"	450mm	21.46	15.84	13.30	4.25	26.84	7.37	4.75	3.48	3.48	.53	1.29	1.06	17.13	235	4800	12150
20"	500mm	23.75	17.38	14.38	5.00	30.00	7.37	5.50	3.90	3.90	.69	1.57	1.42	18.68	275	7800	15600
24"	600mm	28.00	19.12	16.49	5.94	34.50	8.00	5.75	3.90	3.90	.69	1.48	1.42	22.65	420	9400	18800
30"	800mm	35.88	23.00	21.00	6.62	43.00	8.00	5.75	3.90	3.90	.69	1.56	1.42	28.41	750	11000	22000

* Series 485 available in 5" (125mm) to 30" (800mm). Series 486 available in 2" (50mm) to 30" (800mm). Series 487 available in 4" (100mm). Series 488 available in 2" (50mm) and 3" (80mm).

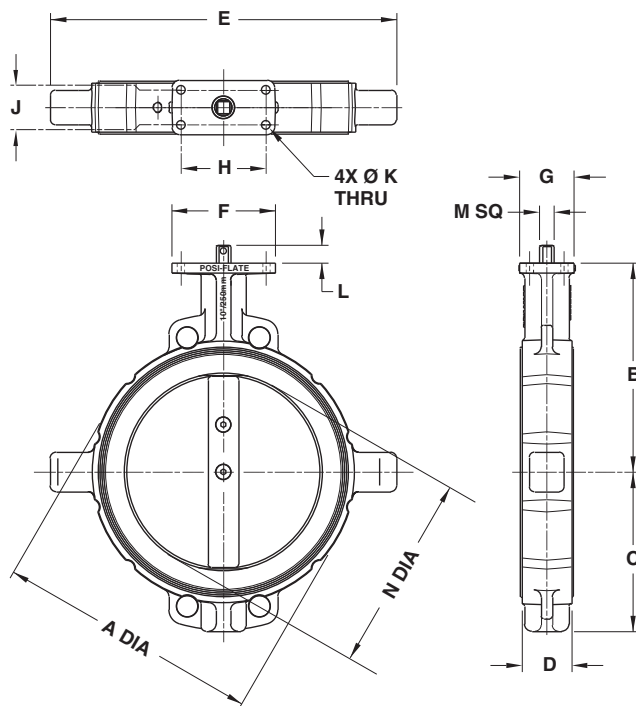

Available Materials of Construction:

Housing: Cast iron, stainless steel, aluminum, nickel-plated cast iron, epoxy coated cast iron, nylon coated cast iron

Resilient Seat: EPDM, Buna-N, polyurethane, fluoroelastomer, FDA silicone, FDA white Buna-N, FDA white EPDM, FDA white fluoroelastomer

Disc: Cast iron, 316 stainless steel (satin or polished), molded nylon. PTFE, nickel and nylon coating available

Bearings: Polymer, bronze

Disc Screws: Carbon steel, stainless steel

Shaft: Zinc-plated carbon steel, 316 stainless steel

Shaft Seal: Buna-N, fluoroelastomer

Housing Gasket: Buna-N (Series 486, 487, 488)

Retaining Ring: Carbon steel, stainless steel

Housing Bolts: Carbon steel, stainless steel

All specifications subject to change without notice. Customized materials available.

Posi-flate® is a registered trademark of Posi-flate, St. Paul, Minnesota.

Made in the U.S.A.

Foreign patents pending.

© Copyright 2016, Posi-flate®

Printed in U.S.A. • Bulletin 9901-6 (dm)

Temperature limits: -40° to 350° F (-40° to 175° C), varies with application and materials of construction.

Air supply: 115 PSIG (7.9 bar) maximum to seat, varies with application.

Working pressure: Full vacuum to 100 PSIG (6.9 bar), varies with materials of construction.

Operating torque: Varies with application.

SERIES 485

Single piece housing with disc and shaft. Sizes 5" (125mm) to 30" (800mm).

SERIES 486

Split housing with integral stainless steel disc and shaft or integral molded nylon disc and stainless steel shaft. Sizes 2" (50mm) to 30" (800mm).

SERIES 487

Split housing with disc and shaft. Size 4" (100mm).

SERIES 488

Split housing with integral cast iron disc and shaft. Sizes 2" (50mm) and 3" (80mm).

posi-flate®
butterfly valves

Corporate Headquarters

Posi-flate • St. Paul, MN USA • +1 651 484 5800

Worldwide Offices

Brazil • China • United Kingdom

www.posiflate.com